



**SERIES B-10 5/8" ROTOR**

- 3 HP   
  5 HP   
  7.5 HP   
  10 HP

**SPECIFICATIONS**

**APPLICATION:** Dishwashing areas and all food prep areas of large restaurants and institutional kitchens.

**SPECIFICATIONS:** Disposer to be a Master Disposer Model B(HP) - (Chamber Style) - (Mounting Assm.) - (Control & Voltage)  
 10 5/8" Diameter Rotor/Turntable with exclusive adjustable 45° angle and 6 integral impact breakers constructed of hardened ductile steel alloy for long life use. Matching 45° Sizing Ring with 24 grind teeth constructed of hardened ductile steel alloy. Exclusive 8 1/4" throat opening to allow for faster feeding. Flexible neoprene collar to eliminate vibration and increase ease of installation. Versatile low body or offset grind chambers with force feed directional deflectors. Bolt on grind chamber allows replacement of all wearing parts without disturbing plumbing and electrical connections. Bolt on discharge flange for easy removal. Adjustable legs to level disposer and meet drain stub. Bolt on "Continuous Duty" motor for easy removal. Exclusive shaft extension with 3/4" wrench flats to externally de-jam foreign matter without special tools. Heavy cast alloy construction providing an extra long life disposer.

**MOUNTING ASSEMBLIES:**

- "SK" 8 1/4" Sink/Trough Adaptor  
 "BC" 12" or 18" Bowl Cone  
 "TC" 12" Transition Cylinder

(All assemblies include; water inlet, vacuum breaker, flow controls, and silver saver)

- "L" LOW CHAMBER (STANDARD)

- "O" OFFSET CHAMBER



**ADAPTORS:** Available for replacing any make disposer with a MASTER

**CONTROL GROUP:** (Includes Solenoid)



- "MAN" Manual Starter

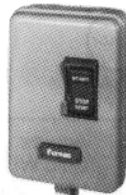

- "MAN REV" Manual Reversing Starter



("MAN" and "MAN REV" NOT AVAILABLE 10H.P.)

**AUTOMATIC REVERSING PREFABRICATED CONTROL CENTERS:**



- "CR" • Auto Rev



- "CRTW" • Auto Rev • Timed Water Afterrun



- "CCRM" • Auto Rev • Timed Water and Motor Afterrun

(For further information see "Controls Specification Sheet" other controls available, consult factory)

**EXAMPLE OF DATA SEQUENCE FOR SPECIFICATION AND ORDERING**

**B 5 - L - SK - CCRM 230/60/3**

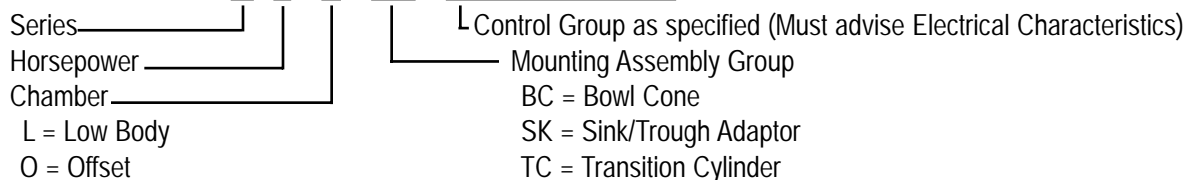

# SERIES "B" INSTALLATION DATA AND DIMENSIONS

## MOTOR DATA

HP	PH	Voltage	Amps.
3	3	208-230/460	10.5/5.25
5	3	208-230/460	17.0/8.5
7½	3	208-230/460	22.0/11.0
10	3	208-230/460	26.0/13.0

Continuous Duty-Dual Voltage and Dual Direction-1750 RPM-60 CY Motors. Full service factor-in accordance with NEMA & NEC electrical codes. Bearings permanently lubricated.

## DISPOSER PLUMBING

**INLET:** ¾" cold water supply at 20 lbs. minimum flow pressure.  
**OUTLET:** 2" female std. thread pipe coupling. Connect directly to drain, not thru grease trap.  
**DRAIN:** Min. slope ¼" per foot. Use recessed thread fitting w/pipe ends reamed/burr-free. Use short horizontal line w/ elbows and tees at minimum, using only long-sweep type. Connected to 3" branch line running into stack. Install with union.  
**IMPORTANT:** Rod and clean drain before using disposer, even in a new installation. Purge water supply line before connecting plumbing accessories.

## SUGGESTED DRAINLINE CONNECTION

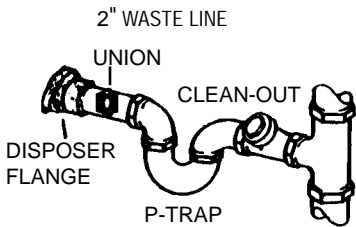

**NOTE:**  
 ALL ELECTRICAL AND PLUMBING CONNECTIONS SHOULD BE MADE ACCORDING TO LOCAL AND AREA CODES.

## TYPICAL INSTALLATION

### 8¼" SINK/TROUGH ADAPTOR 'SK'

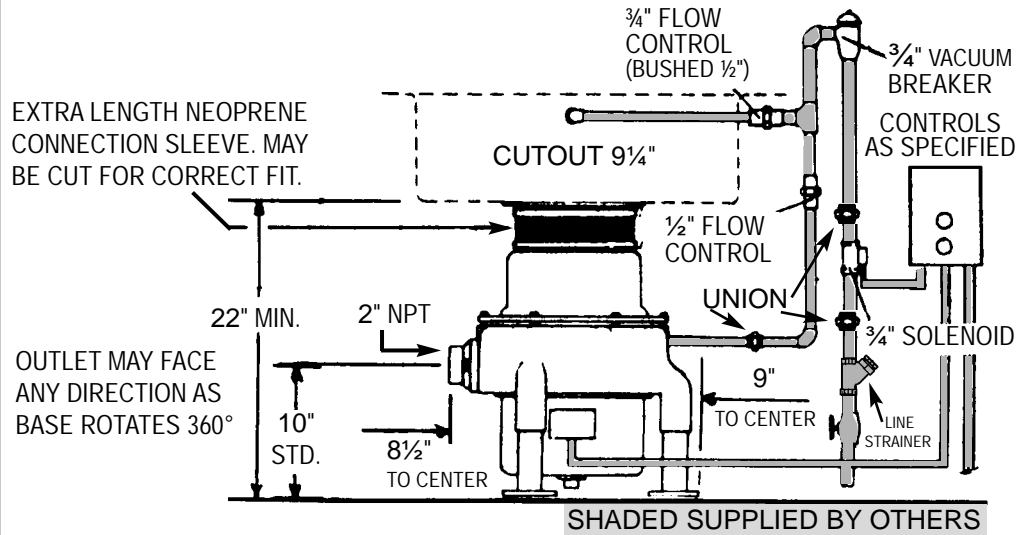

## DIMENSIONS

### 8¼" SINK/TROUGH ADAPTOR 'SK'

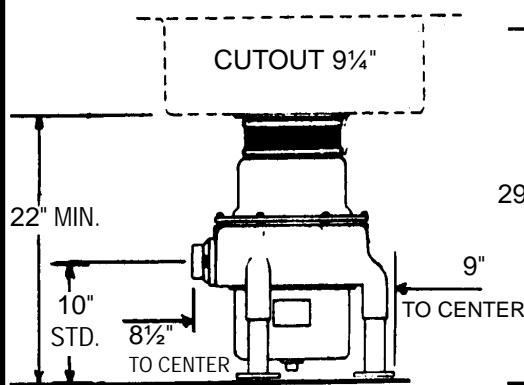

### 18" BOWL / CONE 'BC'

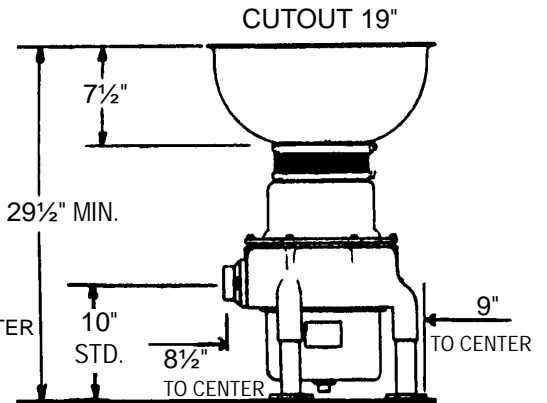

### 12" TRANSITION CYLINDER 'TC'

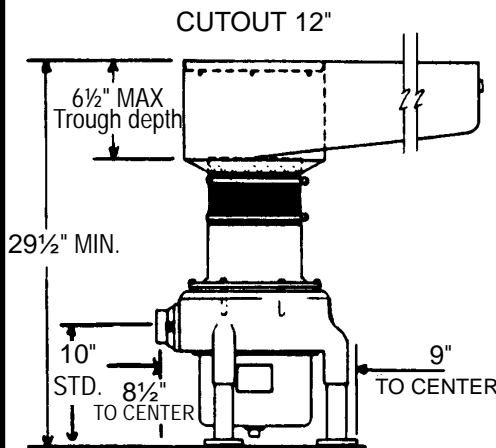

All dimensions are for "L" Low Chamber  
 For "O" Offset Chamber, consult factory.



FORM BS307 PRINTED IN U.S.A.