

**MODEL MC**

For all Master Disposers series.

Model No.	H.P.	Voltage	Phase
MC-1L	1 to 2	115	1
MC-1H	1 to 2	230	1
MC-5L	1 to 10	230	3
MC-5H	1 to 10	460	3

**MC
SERIES
MAGNETIC STARTER
(NON-REVERSING)**

PRODUCT INFORMATION:

■ **APPLICATION:** Provides magnetic contactor control of motor for longer switch life.

■ **DESIGN AND CONSTRUCTION:** High strength compression molded NEMA4X (watertight, corrosion resistant) enclosure. Magnetic contactor with built-in automatic reset overload relay to protect against low voltage, overloads and phase failure. Clearly marked terminal strip for easy connection of incoming power, solenoid valve and remote switch.

■ **WARRANTY:** One full year from date of purchase by end user or eighteen months from date of shipment from factory, covering defects in material or workmanship; parts and labor included.



3RV1923-1.... (3RV1933-1....) [3RV1923-1DA01]

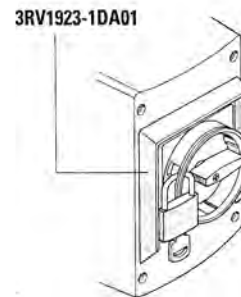
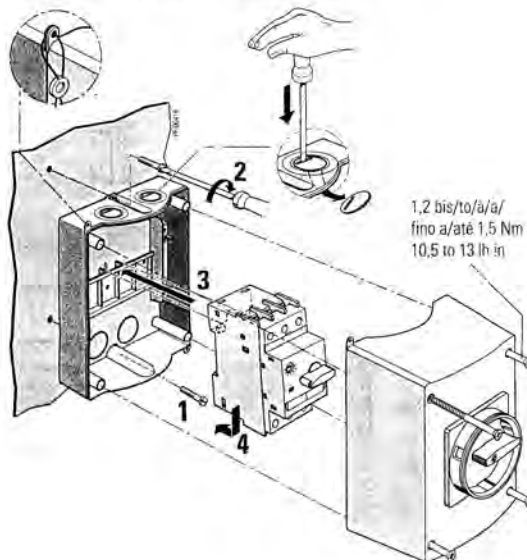

3RV1903-5.

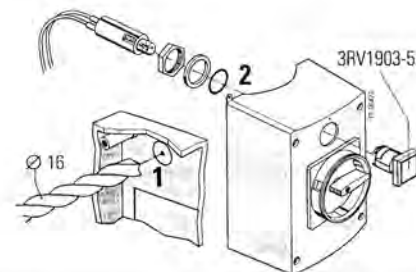

GWA 4NEB 469 0036-10d

Last update: 30 January 2003

Master Disposers

SOMAT COMPANY
165 Independence Court, Lancaster, PA 17601
717-397-5100 — FAX #717-299-4131
800-237-6628 ext. 173 — www.masterdisposers.com

TW Food Equipment Group

**MODEL MC
MAGNETIC STARTER (NON-REVERSING)**

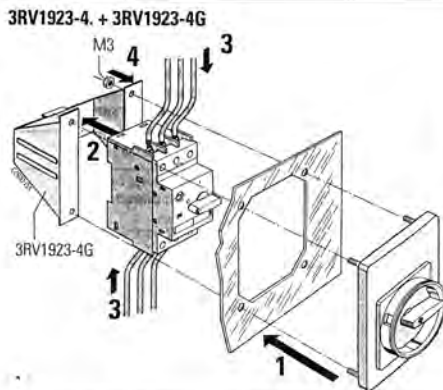
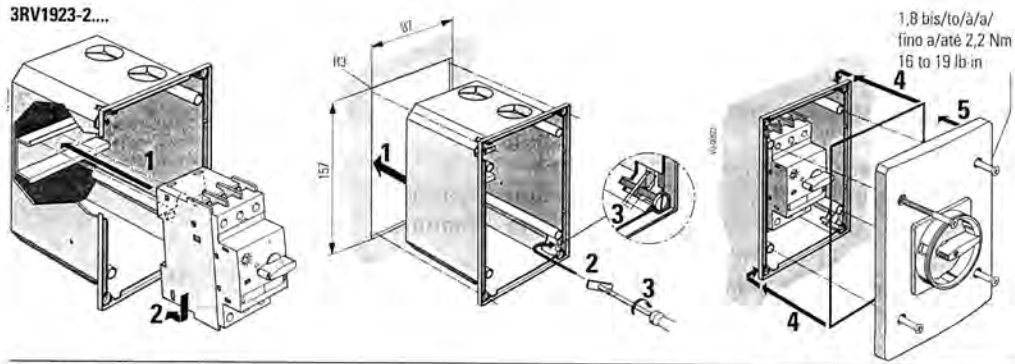

	a
3RV1.2	86,5
3RV1.3	139,0
3RV1.4	164,5

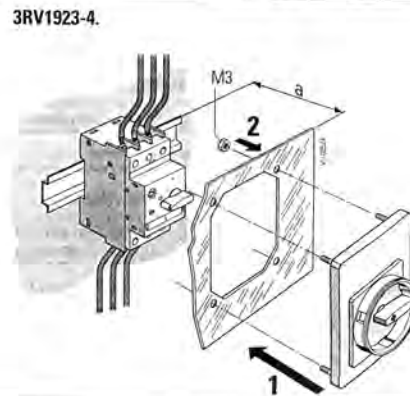

3RV1923-1C.../1D... (3RV1933-1D...) [3RV1923-1DA01]

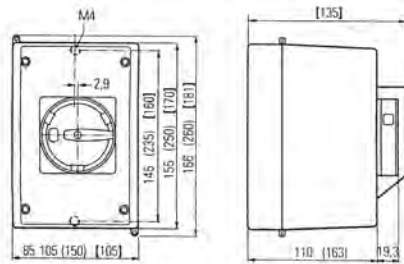

3RV1923-2...

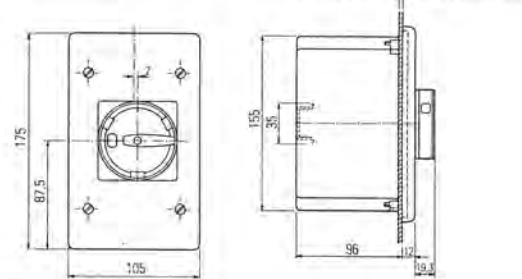

3RV1923-4 + 3RV1923-4G

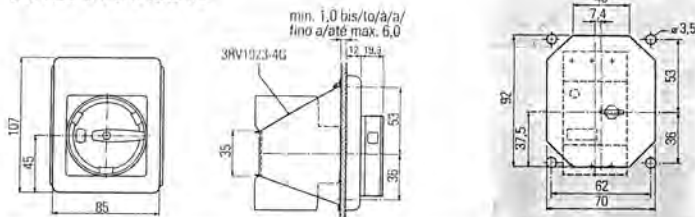

Technical Assistance: Telephone: +49 (0) 9131-7-43833 (8⁰⁰ - 17⁰⁰ CET) Fax: +49 (0) 9131-7-42899
 E-mail: technical-assistance@siemens.com
 Internet: www.siemens.de/lowvoltage/technical-assistance

Technical Support: Telephone: +49 (0) 180 50 50 222

Subject to change without prior notice. Store for use at a later date.
 © Siemens AG 1998

Bestell-Nr./Order No.: 3ZX1012-0RV10-2AA1

Master Disposers is not responsible for any typographical errors. Due to continued product improvement specifications are subject to change without prior notice.

Master Disposers

SOMAT COMPANY
 165 Independence Court, Lancaster, PA 17601
 717-397-5100 — FAX #717-299-4131
 800-237-6628 ext. 173 — www.masterdisposers.com

