



Master Disposers
HEAVY DUTY FOODWASTE DISPOSERS

**MODELS MS-1
MS-2**

**MS
SERIES
MANUAL ON/OFF SWITCH
(NON-REVERSING)**

For "D" series disposers only

Model No.	H.P.	Voltage	Phase
MS-1	1 to 2	115 or 230	1
MS-2	1 to 2	208, 230 or 460	3



PRODUCT INFORMATION:

- **APPLICATION:** Economical non-reversing On/Off switch for use when magnetic contactor and overload protection are not required.
- **DESIGN AND CONSTRUCTION:** NEMA4, watertight, cast aluminum housing and cover. Cast aluminum lever actuator with provision for lockout.
- **WARRANTY:** One full year from date of purchase by end user or eighteen months from date of shipment from factory, covering defects in material or workmanship; parts and labor included.



Consultant/Contractors Approval

Master Disposers

SOMAT COMPANY
165 Independence Court, Lancaster, PA 17601
717-397-5100 — FAX #717-299-4131
800-237-6628 ext. 173 — www.masterdisposers.com

TW Food Equipment Group

**MODELS MS-1 & MS-2
MANUAL ON/OFF SWITCH (NON-REVERSING)**

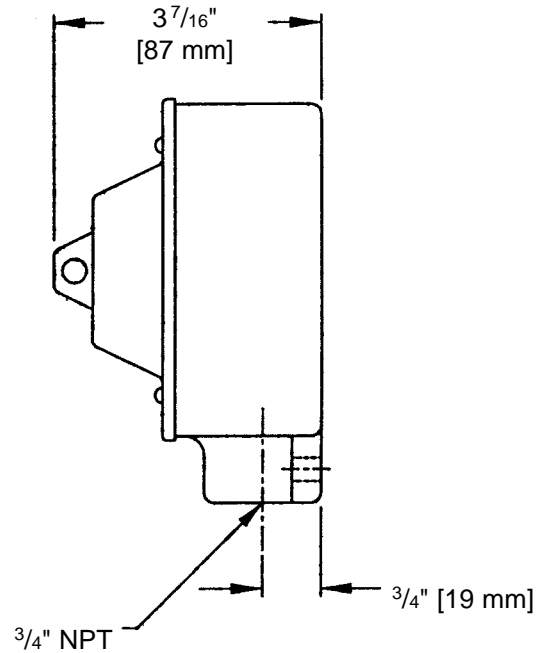
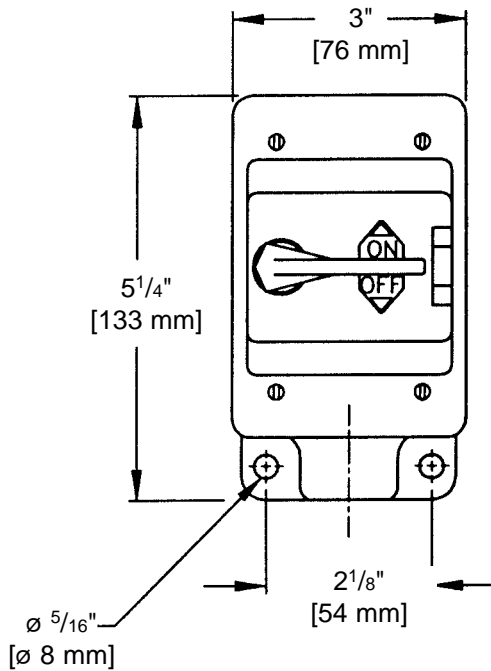

■ **SHIPPING DIMENSIONS AND WEIGHTS:**

MODEL NO.	WIDTH		DEPTH		HEIGHT		WEIGHT		VOLUME	
	in.	mm	in.	mm	in.	mm	lbs.	kg	cu. ft.	cu. m
MS-1	7	178	7	178	3	76	4	2	.09	.002
MS-2	7	178	7	178	3	76	4	2	.09	.002

■ **BID SPECIFICATIONS: (Example)**

Item No. _____ Manual Switch

Manual Switch shall be model MS-2*

Construction: Shall be NEMA4 watertight, cast aluminum enclosure with lever actuator and lock out provisions.

Approvals and Warranty: Shall be UL (Underwriters Laboratories, Inc.) listed. Warranty shall cover parts, labor and mileage on all components for one year.

* **Specify HP, Voltage, and Phase when ordering**

Master Disposers is not responsible for any typographical errors. Due to continued product improvement specifications are subject to change without prior notice.

Master Disposers

SOMAT COMPANY
165 Independence Court, Lancaster, PA 17601
717-397-5100 — FAX #717-299-4131
800-237-6628 ext. 173 — www.masterdisposers.com

TW Food Equipment Group