

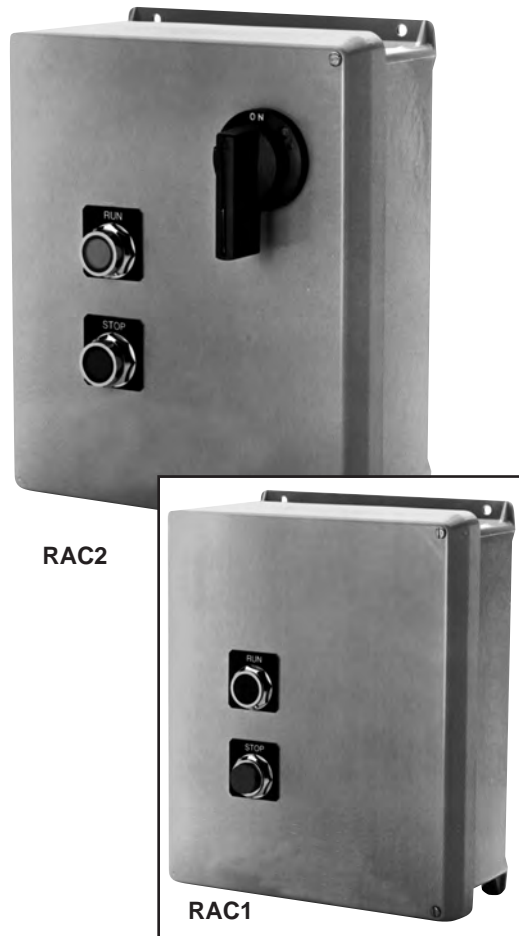

Master Disposers
HEAVY DUTY FOODWASTE DISPOSERS

**MODELS RAC 1
RAC 2**

**RAC1 & RAC2
SERIES
AUTOMATIC REVERSING
MAGNETIC CONTROLS**



Model No. RAC1 Series	Model No. RAC2 Series	H.P. Range	Voltages*		PH
			L	H	
√ RAC1-0*	√ RAC2-0*	1	115	230	1
√ RAC1-1*	√ RAC2-1*	2	115	230	1
√ RAC1-2*	√ RAC2-2*	1 & 2	208/230	460	3
RAC1-1.5*	RAC2-1.5*	1.5 & 2	208/230	460	3
RAC1-2.5*	RAC2-2.5*	1.5	115	230	1
RAC1-5*	RAC2-5*	3 to 5	208/230	460	3
RAC1-7*	RAC2-7*	7.5	208/230	460	3
RAC1-10*	RAC2-10*	10	208/230	460	3

* - Indicate voltage by adding **L** or **H** to the end of model number.
√ - used for "D" series only

OPTIONS:

- PF: Positive flush.
- RS: Remote Start/Stop switch.
- EM: The *Eco-Mizer*™ Electricity and Water Saver.

PRODUCT INFORMATION:

- **APPLICATION:** Provides automatic reversing of motor (the motor runs in the opposite direction each time it is started) which doubles the life of the shattering mechanism.
- **DESIGN AND CONSTRUCTION:** High strength compression molded glass fiber reinforced polyester, NEMA4X (watertight, corrosion resistant) enclosure. Reversing magnetic contactors with built-in automatic reset overload relays to protect against low voltage, overloads and phase failure. Clearly marked terminal strip for easy connection of incoming power, solenoid valve and remote switch.
- **DESIGN FEATURES:** Encapsulated solid state control circuit board with self-diagnostic circuitry and indicator lights. Front mounted, heavy duty Start and Stop pushbuttons. RAC2 Series features illuminated pushbuttons to indicate mode of operation, built-in clean out cycle (2 minute time delay for flushing of disposer and waste lines) and disconnect switch with heavy duty front mounted "pistol grip" handle with provision for lockout. Anti-plug relay to prevent motor reversing while running or coasting.
- The *Eco-Mizer*™ Electricity and Water Saver conserves water and electricity usage by limiting disposer run time to a preset interval. Specify 5 to 15 minutes.
- **WARRANTY:** One full year from date of purchase by end user or eighteen months from date of shipment from factory, covering defects in material or workmanship; parts and labor included.

Consultant/Contractors Approval



Master Disposers

SOMAT COMPANY
165 Independence Court, Lancaster, PA 17601
717-397-5100 — FAX #717-299-4131
800-237-6628 ext. 173 — www.masterdisposers.com

TW Food Equipment Group

MODELS RAC1 & RAC2 AUTOMATIC REVERSING MAGNETIC CONTROLS



■ DIMENSIONS:

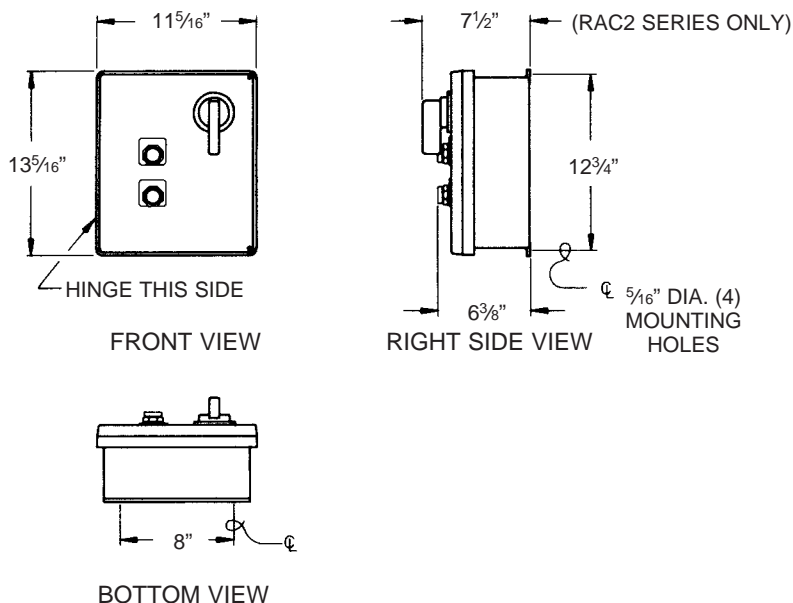

■ TYPICAL INSTALLATION:

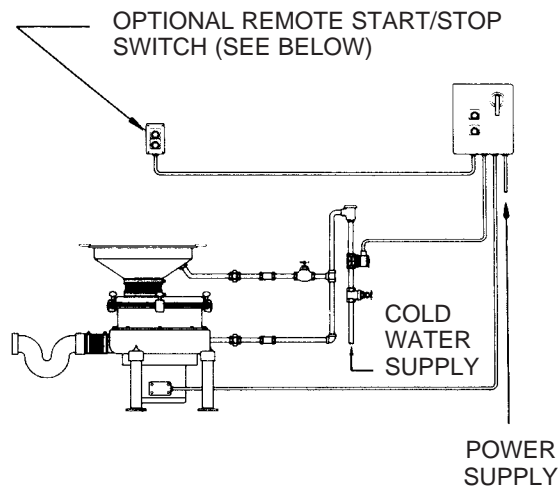

■ SHIPPING DIMENSIONS AND WEIGHTS:

MODEL NO.	WIDTH		DEPTH		HEIGHT		WEIGHT		VOLUME	
	in.	mm	in.	mm	in.	mm	lbs.	kg	cu. ft.	cu. m
RAC1	12	305	14	356	11	279	25	11	1.1	.03
RAC2	12	305	14	356	11	279	28	13	1.1	.03

■ BID SPECIFICATIONS: (Example)

Item No. _____ Control Center

Control Center shall be Master Disposer model RAC2-5L

Construction: Shall be NEMA4X watertight, corrosion resistant, molded glass fiber reinforced polyester enclosure. Reversing magnetic contactors with overload relay to protect against low voltage, motor overload and phase failure. Front mounted heavy duty illuminated pushbuttons. Built in front-mounted disconnect switch with heavy duty pistol grip handle with provision for lockout. Encapsulated (moisture resistant) solid state low voltage control circuit with self diagnostic indicator lights. Anti-plug relay to prevent motor reversing while running or coasting. Clean out cycle 2 minute time delay. Shall include the **Eco-Mizer™** Electricity and Water Saver preset at factory to customer requirements, 5 to 15 minutes, at no additional cost.

Approvals and Warranty: Shall be UL (Underwriters Laboratories, Inc.) listed. Warranty shall cover parts, labor and mileage on all components for one year.

■ OPTIONS:



MODEL RS: REMOTE START/STOP SWITCH

Allows control panel to be located a distance away while Start/Stop switch can be mounted near disposer. NEMA4X enclosure. *Additional Cost*

MODEL PF: POSITIVE FLUSH

Leaves water running for flushing of waste chamber and drainline for two minutes after motor stops.

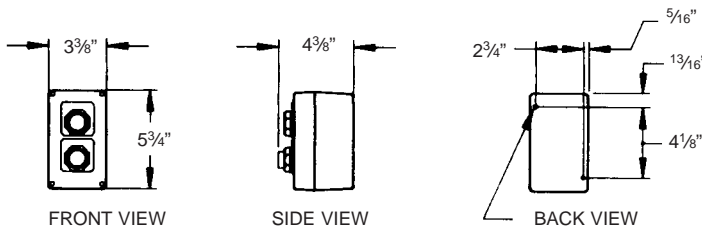

Master Disposers is not responsible for any typographical errors. Due to continued product improvement specifications are subject to change without prior notice.

Master Disposers

SOMAT COMPANY
165 Independence Court, Lancaster, PA 17601
717-397-5100 — FAX #717-299-4131
800-237-6628 ext. 173 — www.masterdisposers.com

TW Food Equipment Group