



Master Disposers

HEAVY DUTY FOODWASTE DISPOSERS

SERIES A 15" ROTOR

AVAILABLE IN 5, 7.5, 10 HP

Discontinued Manufacturing as of 9/1/09

APPLICATION: Mass feeding institutions and central waste rooms, salad commissaries, or large produce prep station.

SPECIFICATIONS: Disposer to be a Master Disposer Model A(HP) - (Chamber Style) - (Mounting Assm.) - (Control & Voltage)
15" Diameter Rotor/Turntable with exclusive 2 piece design and 10 integral impact breakers constructed of hardened ductile steel alloy for long life use. Matching Sizing Ring with 40 grind teeth constructed of hardened ductile steel alloy. Exclusive 8 1/4" throat opening to allow for faster feeding. Flexible neoprene collar to eliminate vibration and increase ease of installation. Versatile low body or offset grind chambers with force feed directional deflectors. Bolt on grind chamber allows replacement of all wearing parts without disturbing plumbing and electrical connections. Bolt on discharge flange for easy removal. Adjustable legs to level disposer and meet drain stub. Bolt on "Continuous Duty" motor for easy removal. Exclusive shaft extension with 3/4" wrench flats to externally de-jam foreign matter without special tools. Heavy cast alloy construction providing an extra long life disposer.

MOUNTING ASSEMBLIES:

"SK" 8 1/4" Sink Adaptor

"BC" 12" or 18" Bowl Cone

(All assemblies include; water inlet, vacuum breaker, flow controls, solenoid valve, and silver saver)

"L" LOW CHAMBER (STANDARD)

"O" OFFSET CHAMBER



ADAPTORS: Available for replacing any make disposer

CONTROL GROUP:



MC
Magnetic Contactor w/ Overload Protection

("MS-1", "MS-2", and "RMS-2" NOT AVAILABLE FOR "B" SERIES)

AUTOMATIC REVERSING CONTROL CENTERS:



RAC1
Auto Rev
Timed Water Afterrun
Timed Motor Afterrun
Auto Off Feature



RAC2
Auto Rev
Timed Water Afterrun
Timed Motor Afterrun
Auto Off Feature
Lighted Push Buttons
Line Disconnect Handle

EXAMPLE OF DATA SEQUENCE FOR SPECIFICATION AND ORDERING

A 5 - L - SK - RAC2 230/60/3

Series
Horsepower
Chamber
L = Low Body
O = Offset

Control Group as specified (Must advise Electrical Characteristics)
Mounting Assembly Group
BC = Bowl Cone
SK = Sink Adaptor

SERIES "A" INSTALLATION DATA AND DIMENSIONS

TYPICAL INSTALLATION

8 1/4" SINK ADAPTOR 'SK'

MOTOR DATA			
HP	PH	Voltage	Amps.
5	3	208-230/460	17.0/8.5
7 1/2	3	208-230/460	22.0/11.0
10	3	208-230/460	26.0/13.0

Continuous Duty-Dual Voltage and Dual Direction-1750 RPM-60 CY Motors. Full service factor-in accordance with NEMA & NEC electrical codes. Bearings permanently lubricated.

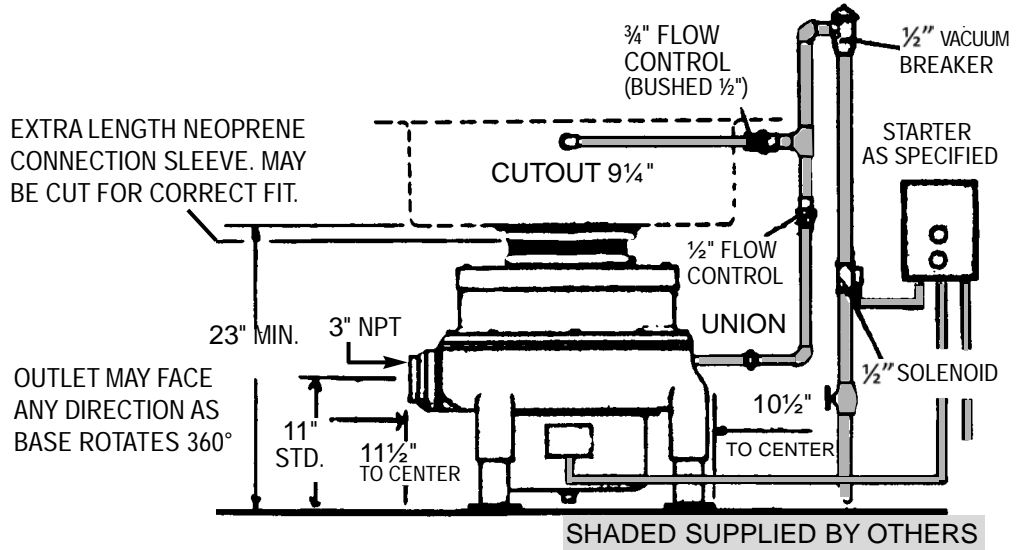

DISPOSER PLUMBING

INLET: 1/2" cold water supply at 20 lbs. minimum flow pressure.
 OUTLET: 3" female std. thread pipe coupling. Connect directly to drain, not thru grease trap.
 DRAIN: Min. slope 1/4" per foot. Use recessed thread fitting w/pipe ends reamed/burr-free. Use short horizontal line w/ elbows and tees at minimum, using only long-sweep type. Connected to 3" branch line running into stack.
 IMPORTANT: Rod and clean drain before using disposer, even in a new installation.

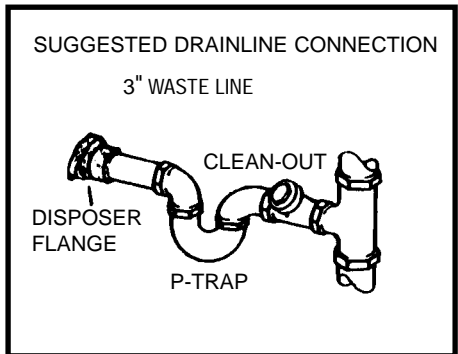

DIMENSIONS

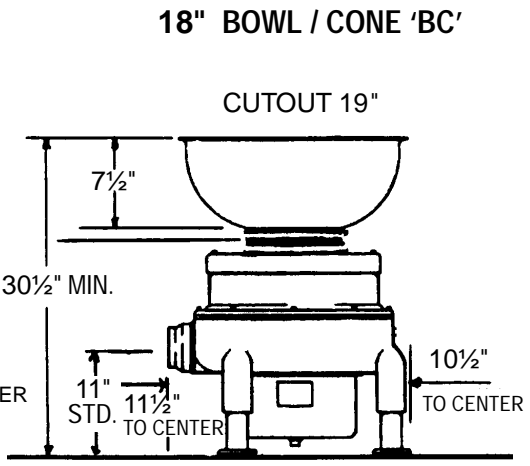
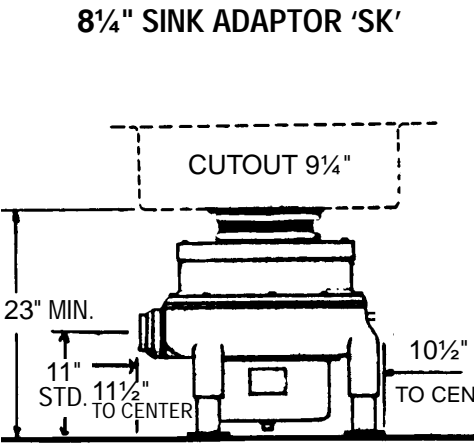

NOTE:
 ALL ELECTRICAL AND PLUMBING CONNECTIONS SHOULD BE MADE ACCORDING TO LOCAL AND AREA CODES.



Master Disposers

SOMAT COMPANY
 165 Independence Court, Lancaster, PA 17601
 717-397-5100 — FAX #717-299-4131
 800-237-6628 ext. 173 — www.masterdisposers.com

